

PACKAGED ICE PALLETIZING SYSTEM



AUTOMATED INDUSTRIAL TECH



AUTOMATED INDUSTRIAL TECH

SMALL FOOTPRINT | COST EFFECTIVE | EASY TO OPERATE

Palletize:

Cases | Bags | Trays

Up to 50 lbs., run speeds between 35-40 bags per minute

COST-EFFECTIVE PACKAGE PALLETIZING

- 35-40 bags per/min (size dependent)
- Powder-Coated Steel construction
- Brand name components
- Servo control for speed and accuracy
- 230/480v - 3 phase power
- Low air consumption 5-6 SCFM
- WEB server for remote diagnostic or program change
- PLC with touch screen control
- Easily convert single chamber to dual chamber
- Auto product reject system. Eliminating faulty packages from being palletized.
- Lifts up to 50 lb. cases, bags, or trays
- Upstream equipment communication

The Series 100i and Series 200i from **Automated Industrial Tech** are semi-automatic palletizing systems that are cost effective, easy to operate, and have small footprints. The Series 100i utilizes a single chamber while the Series 200i is a dual chamber machine. These automated solutions use uncomplicated design principles and have reliable brand name components to ensure serviceability and ease of operation.

These systems palletize packaged goods such as packaged ice, pellet fuel, packaged mulch, packaged fertilizer, packaged beverages, and more.

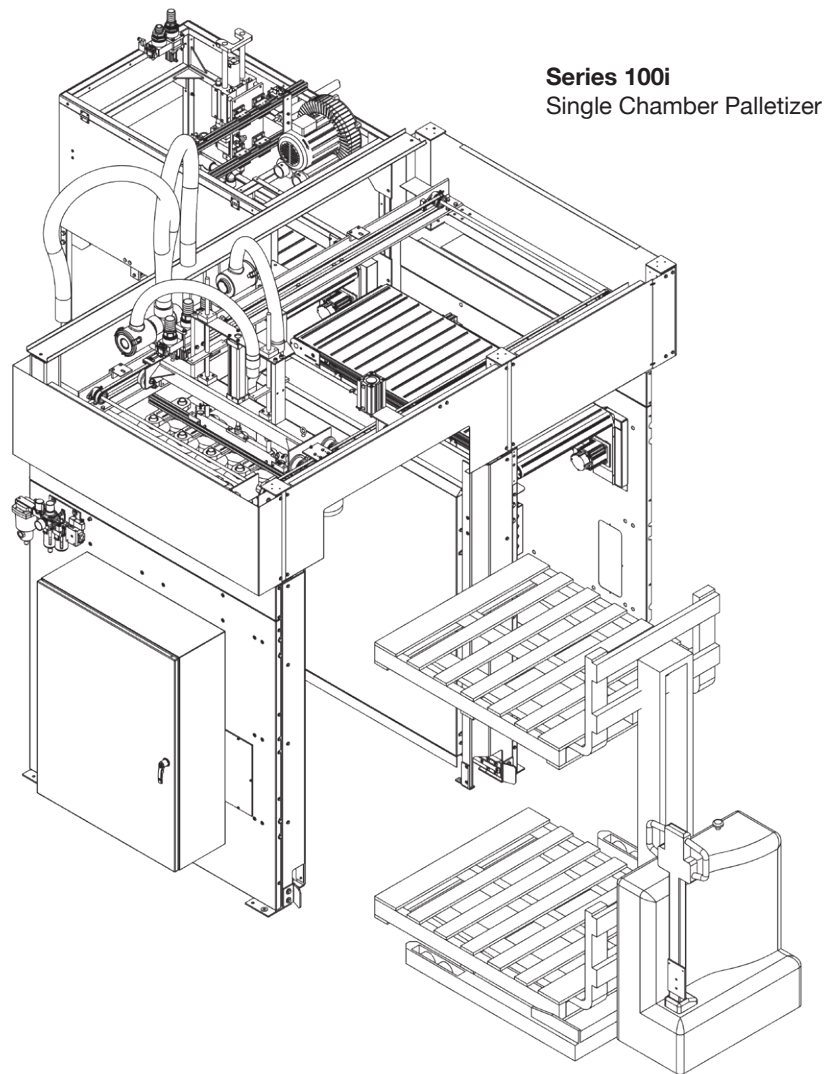

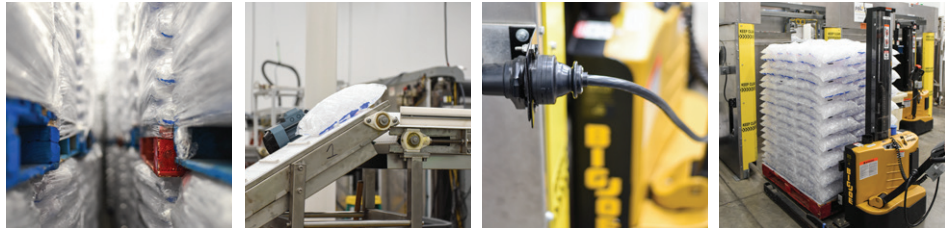

SERIES 100i, 200i FEATURES

Safety

- ANSI/OSHA Approved
- Lock Out/Tag Out
- Completely Safeguarded
- Multiple E-Stops

Color Touchscreen Control

- Diagnostics
- Layer and Pattern Setup
- Product change
- I/O Manual Control
- User Friendly
- Password Protected

Robust Construction

- Powder-Coated Steel Construction
- Stainless Steel (Optional)
- UHMWPE or STSTL where product makes contact

Servo Control Index System

- Precise
- Fast
- Reliable

“As much as I loved the original Raesco the thought of eliminating the lift system and all of its moving parts and stress points by going with a completely independent Big Joe straddle stacker lift was an idea I couldn't wait for. Installation was quick and easy, less than 12 hours. I placed an order for a second one after only two weeks in operation.”

— Doug Arrington
OWNER HOMETOWN ICE



MORE OPERATIONAL UPTIME AND FEWER DISRUPTIONS

- 40 x 48 GMA or Chep pallets
- Manually remove pallet and replace with straddle truck
- Series 100i - pallet change one minute or less
- Series 200i - production never stops
- Load walls expand and retract for tight pallet load. Eliminate damaged bags while loading truck.
- Small Footprint, 100-200 Square/Feet
- Cost effective, quick return on investment
- Air: 100 PSI at 5-6 SCFM
- Servo control for speed and accuracy

Palletize up to one ton per pallet

- Bags
- Cases
- Trays
- Shrink Bundles

